

RYAN N. PATTERSON
MANAGER-CLERK
ST. JOHNS, AZ 859

**BOARD OF SUPERVISORS
OF APACHE COUNTY**

P.O. BOX 428
ST. JOHNS, ARIZONA 85936

TELEPHONE: (928) 337-7503
FACSIMILE: (928) 337-2003

JOE SHIRLEY, JR.
CHAIRMAN OF THE BOARD
DISTRICT I
P.O. Box 1952, Chinle, AZ 86503

ALTON JOE SHEPHERD
VICE CHAIRMAN OF THE BOARD
DISTRICT II
P.O. Box 994, Ganado, AZ 86505

NELSON DAVIS
SUPERVISOR
DISTRICT III
P.O. Box 428, St. Johns, AZ 85936

**NOTICE OF A PUBLIC MEETING AND AGENDA
OF THE APACHE COUNTY BOARD OF SUPERVISORS**

February 22, 2024

**Board of Supervisors' Hearing Room, First Floor
75 West Cleveland Street
St. Johns, Arizona
1:00 p.m. MST**

Pursuant to A.R.S. §38-431.02(H), the public will have physical access to the meeting room thirty (30) minutes prior to the start of the meeting.

1. Engineering Department: Discussion and possible approval to add Attachment C to Intergovernmental Agreement Contract #CO15355 with the Navajo Nation, for specific special projects within the Navajo Nation. This attachment provides funding for the Carrizo Pit development and N8070 near Rock Point in the total amount of \$983,333.
2. Engineering Department: Discussion and possible approval to utilize sole source vender, Southwest Scale Company, for the purchase and installation of a new 70 x 10 truck scale at the Carrizo Pit, at a cost of \$144,750.
3. Engineering Department: Discussion and possible approval to utilize Sourcewell Contract #58053 with Empire CAT to purchase a new generator for use at the Carrizo Pit, in the amount of \$67,702.
4. Engineering Department: Discussion and possible approval to utilize State Contract Contract # CTR069677 with American Fence Company to install a perimeter security fence around the Carrizo Pit, in the amount of \$231,469.

Pursuant to the Americans with Disabilities Act, the Apache County Board of Supervisors endeavors to ensure the accessibility of its meetings to all persons with disabilities. If you need accommodation for a meeting, please contact the Clerk of the Board's office at (928)337-7503, TDD (928)-337-4402 so that accommodation can be arranged. Members of the Board of Supervisors may participate telephonically or through video communication.

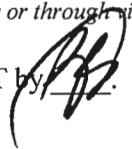
Posted this 21st day of February, 2024 at 11:00 a.m. MST by 

Ryan N. Patterson, Clerk of the Board

**Apache County Board of Supervisors
AGENDA ITEM REVIEW FORM**

Submitter's Name: (Individual, Organization, or County Department)

Engineering

Date/Signature 2/21/24 

Describe in detail what you want to say to the Board and what action you want the Board to take:

Discussion and possible approval to add Attachment C to the Intergovernmental Agreement Contract CO15355 with the Navajo Nation for specific projects within the Navajo Nation. This Attachment provides funding for the Carrizo Pit development and N8070 near Rock Point. For a total of \$983,333.00

BOS Meeting Date Requested 2-22-2024

PRE-AGENDA ITEM REVIEW

Review Routing / /Legal / /Finance / /Purchasing / /Human Resource / /Other: _____

Legal Review: OK per Michael

Signature: _____

Finance Review: _____

Signature: 

Human Resources Review: _____

Signature: _____

Other Review: _____

Signature: _____

Reviews completed; item approved for Agenda. Supervisor/Board Clerk's Initials _____

ATTACHMENT C

**To Intergovernmental Agreement between
The NAVAJO NATION and APACHE COUNTY, ARIZONA**

Authority:

This attachment c is appended to the underlying Master Intergovernmental Agreement, Navajo Nation Contract No. CO15355, as contemplated in Sections 1.1 and 2.1 of the Master Agreement.

Term:

Beginning upon signatures of both parties and Ending December 31, 2032; coinciding with the term of the Master Agreement.

Scope of Work (SOW):

Project 1 – Carrizo Pit Development Navajo Division of Transportation (NDOT) will provide Navajo Nation Fuel Excise Tax funds for the Carrizo Pit development in the amount of \$150,000.00 as stated in the Navajo Nation Resources and Development Committee Resolution RDCO-0076-17, dated February 8, 2017. These funds will be used for pit development, fence, signs and other miscellaneous items needed to continue the development of the Carrizo Pit.

The primary goal is to establish the Carrizo Pit and share the aggregate material between Apache County and Navajo Division of Transportation for school bus routes and road improvements located within vicinity of Carrizo Pit as stated in the Carrizo Pit General Mining Plan. Apache County and NDOT have invested in required clearances and permits fees, time, and additional tasks, to accommodate the Carrizo Pit General Mine Plan initiative.

Should any of these Scopes of Work or any additional work exceed the amount of the funding source as described herein, the Chapters and Navajo Nation shall find additional sources.

Budget:

Project #	District	Project Name	Funding Source	Business Unit	Budget
1	D-1	Carrizo Pit Development	NN Fuel Excise Tax		150,000.00
Total Attachment "C" Project 1					150,000.00

Project 2 – Rock Point, Arizona, Navajo Route N8070. NDOT will provide Navajo Nation Sihasin funds for Rock Point Navajo Route N8070 in the amount of \$833,333.00 as stated in the Navajo Nation Council Resolution CAP-21-21, dated April 27, 2021 and signed into law on May 6, 2021.

The primary goal is to provide a suitable roadway on Route N8070 for the school bus route located within the Rock Point Arizona Chapter. The project Scope of Work shall consist of grade, drain and improvement of the roadway including and required permit fees. There are sections of the route where runoff causes damage to the existing roadway and creating flooding during storm events. This Project will address drainage issues and provide a passable roadway.

Should any of these Scopes of Work or any additional work exceed the amount of the funding source as described herein, the Chapters and Navajo Nation shall find additional sources.

Budget:

Project #	District	Project Name	Approving Resolution Funding Source	Business Unit	Budget
1	D-1	Rock Point Route 8070	CAP-21-21 NN Sihasin Funds		833,333.00
Total Attachment "D" Project 2					833,333.00

TOTAL ATTACHMENT "C" NOT TO EXCEED:

\$983,333.00

IN THE WITNESS WHEREOF, the PARTIES have executed this ATTACHMENT "C" to the Master Intergovernmental Agreement, on the dates affixed by their signatures.

APACHE COUNTY

THE NAVAJO NATION

Dr. Joe Shirley, Jr., Chairman
Apache County Board of Commissioners
P.O. Box 48
St. Johns, AZ 85936

Buu Nygren, President
The Navajo Nation
P.O. Box 7440
Window Rock, AZ 86515

Date Signed

Date Signed

THIS CONTRACT HAS BEEN REVIEWED
AND IS IN ACCORDANCE WITH NAVAJO NATION LAW

BY _____
Navajo Nation Legal Counsel

Date Signed

THE NAVAJO NATION

JONATHAN NEZ | PRESIDENT MYRON LIZER | VICE PRESIDENT



June 8, 2022

APACHE COUNTY, ARIZONA

Nelson Davis, Chairman, Board of Supervisors
Post Office Box 428
St. Johns, Arizona 85936

Reference: DOC 018527 – CO15355

Dear Mr. Davis:

Attached, please find your executed Intergovernmental Agreement Contract, **CO15355**. This Intergovernmental Agreement Contract is with the Navajo Nation Division of Transportation. This Intergovernmental Agreement Contract is approved in the amount of One Hundred Eighty-Five Thousand Three Hundred Dollars and Zero Cents (\$185,300.00).

This Intergovernmental Agreement Contract will commence on May 18, 2022 and will terminate on December 31, 2032. Contract, **CO15355** must be referenced on all invoices, documents and correspondences as it relates to this contract.

Should you have any questions, please contact Garret Silversmith, Director, Navajo Nation Department of Transportation at 505.371.8373.

Sincerely,

THE NAVAJO NATION

Handwritten signature of Valerie Bitsilly in black ink.

Valerie Bitsilly, Accountant
Contract Administration
Navajo Nation Office of the Controller

Xc: Garret Silversmith, Director, Navajo Nation Department of Transportation
 File / Chrono

**INTERGOVERNMENTAL AGREEMENT
BETWEEN THE NAVAJO NATION
AND
APACHE COUNTY, ARIZONA**

THIS INTERGOVERNMENTAL AGREEMENT ("IGA") is made and entered into by and between the Navajo Nation, acting through its Navajo Division of Transportation (the "NATION"), and Apache County, a political subdivision of the State of Arizona, acting through its Board of Supervisors, (the "COUNTY").

WHEREAS, by the adoption of Resources and Development Committee Resolutions the NATION has previously approved road maintenance projects for certain public roads within Apache County and the Navajo Nation and may from time to time approve additional such projects (all such projects to be collectively referred to herein as the "PROJECTS"); and

WHEREAS, the NATION is a sovereign entity and has the inherent power to plan and develop an integrated transportation network of highways, roads, waterways, airports, railroads, and pipelines; and

WHEREAS, the COUNTY is authorized by A.R.S §11-952 to enter into intergovernmental agreements for joint or cooperative action with agencies of the United States and/or Tribal governments; and

WHEREAS, the NATION and the COUNTY have previously entered into a Memorandum of Understanding dated July 14, 2021 (the "MOU"), expressing their intent to cooperate in transportation-related projects for their mutual benefit; and

WHEREAS, consistent with the MOU, the COUNTY has agreed to assist the NATION and individual Chapters of the NATION by acting as their agent for the procurement of materials and supplies required to complete the PROJECTS, providing project planning support, and as agreed on a project-by-project basis to provide labor and equipment to assist in road repair activity for PROJECTS which are eligible for such activity by the COUNTY under the applicable Arizona statutes and constitutional provisions.

NOW, THEREFORE, the parties hereby agree as follows:

1. **Purpose.** The purpose of this IGA is for the COUNTY to assist the NATION and individual Chapters of the NATION by acting as their agent for the procurement of road materials and supplies for the PROJECTS; providing project planning assistance to the Nation and the Chapters in connection with the PROJECTS; and, as may be agreed by Apache County on a project-by-project basis, assisting in road repair activities for PROJECTS which are eligible for such activities by the COUNTY under the applicable Arizona statutes and constitutional provisions. All other work in connection with the PROJECTS, including but not limited to permitting, shall be the responsibility of the NATION. The Statement of Work (SOW) is described in Attachment A for additional information. All other work in connection with the PROJECTS, including but not limited to permitting, shall be the responsibility of the NATION.

Unless otherwise agreed to in writing, the COUNTY shall have no responsibility for the maintenance or repair of any work done pursuant to this Agreement after the completion of a PROJECT.

1.1 **Initial and Additional PROJECTS**. The initial PROJECT is described in Attachment A hereto. From time to time, the parties may agree to additional PROJECTS, each such additional PROJECTS to be described in a separate Attachment to be appended to this IGA with the written approval of the authorized representatives of both parties. Any such additional PROJECT shall be governed by the terms of this IGA.

2. **Funding** For the PROJECT as described in Attachment A, the NATION has set aside up to One hundred, eighty-five thousand, three hundred dollars(\$185,300.00) as payment to the COUNTY for materials, equipment costs, labor and supplies procured for the PROJECT in connection with the PROJECT.

2.1 Funding for Additional PROJECTS. For each additional PROJECT as described in Section 1.1 above, the funding source for such PROJECT shall be set forth in the Attachment describing that PROJECT.

3. **Appropriations**. The NATION warrants that the sum referenced in Section 2 above has been set aside in the Navajo Nation Road Fund and/or General Fund allocations for the purposes set forth in Section 2 and Attachment A.
4. Key Officials. The key officials for each party are as follows:

Apache County

Mr. Ferrin Crosby
Engineering Department
P.O. Box 238
St. Johns, Arizona 85936
Office: (928) 337-7528
Fax: (928) 337-2062

Navajo Nation

Mr. Garret Silversmith
Navajo Division of Transportation
P.O. Box 4620
Window Rock, Arizona 86515
Office: (505) 371-8301
Fax: (505) 371-8399

5. **Need for Materials, Supplies, Road Repair Activity and Project Planning Support**. The parties shall jointly agree on the materials and supplies required for the PROJECTS before each procurement is made. The COUNTY shall agree to the level and type of support it will provide to assist the NATION on the road repair activity. The COUNTY will provide project planning assistance and guidance in determining what materials and supplies are required. Additional project planning support may be provided by the COUNTY as requested by the NATION, but it is understood that the completion of the PROJECTS is the responsibility of the NATION and/or the Chapters which will benefit from the PROJECTS. If the COUNTY will be acting in any capacity other than that of a procurement agent in connection with a PROJECT, the NATION and/or Chapters shall provide such documentation as the COUNTY may reasonably require that the PROJECT roads are eligible for expenditures of COUNTY resources under the applicable Arizona statutes and constitutional provisions.
6. **Procurement Procedures**. Unless otherwise agreed in writing by the parties, all materials and supplies procured by the COUNTY pursuant to this IGA shall be procured in accordance with the Arizona Procurement Code and the Apache County Procurement Policy. Procurement shall include the delivery of the materials and supplies by the vendor to the site(s) where they are required.

7. **Payment to the COUNTY.**

- A. The NATION shall advance funding for each PROJECT prior to any material being ordered. For materials, supplies, equipment, and labor, the NATION shall pay the COUNTY for the actual cost and any directly related procurement expenses (newspaper ads, etc.). The COUNTY shall not charge the NATION any overhead or administrative expenses for procurement and project planning services under this IGA. If the advanced funds are not adequate to complete the PROJECT, the NATION shall advance additional funds within 30 days after receipt of a written request by the COUNTY; the COUNTY shall have no obligation to continue with any PROJECT for which adequate funding has not been received.
 - B. Costs incurred before the finalization of this Agreement which are deemed reasonable, allowable, and allocable to performance of the Agreement as agreed to by the parties may be paid.
 - C. The COUNTY will provide a quarterly report showing expenditures against the advance.
 - D. Each quarterly report shall reference this IGA and the appropriate Attachment.
 - E. The COUNTY shall provide for strict accountability of all cost of materials, supplies, equipment, and labor Applied against the advance, shall maintain an accurate accounting of all PROJECT-related expenditures, and shall preserve such records for at least three (3) years following the final payment under this IGA. Copies of all correspondences, reports and invoices associated with this IGA shall be furnished to the NATION
8. **No Surplus Funds.** Upon completion of each PROJECT and at the termination of this IGA, there shall be no surplus money on hand because all funds advanced will have been disbursed on PROJECT expenditures or returned to the NATION. The COUNTY shall refund surplus funds to the NATION 30 days after parties mutually agree a PROJECT is complete.
9. **Assignment.** The COUNTY shall not assign or transfer any interest in this IGA or assign any claims for reimbursement under this IGA without the prior written approval of the NATION. The COUNTY shall not assign any of its responsibilities under this IGA without the prior written approval of the NATION.
10. **Term.** This IGA shall not become effective until executed by both the President of the Navajo Nation and the Chairman of the Apache County Board of Supervisors. This IGA shall terminate on December 31, 2032, bringing it into concurrence with the MOU timeline.
11. **Amendment/Renewal.** This IGA shall not be altered, changed or amended except by a written instrument executed by both parties on or before the scheduled date of termination, this IGA may be renewed for one or more additional years with the written concurrence of both parties.
12. **Termination.** Either party may terminate this IGA, or its participation in any PROJECT, upon written notice thirty (30) prior to the effective date of termination. Upon such termination, reimbursement, not covered by the advance, shall be made for materials and supplies procured and project planning support provided prior to the date of termination. Money advanced to the COUNTY but not spent or committed shall be refunded to the NATION prior to the date of termination.

13. **Scope of Agreement.** This IGA incorporates all of the agreements, covenants and understandings between the parties hereto concerning the subject matter hereof, and all such covenants, agreements and understandings have been merged into this IGA. No prior agreement or understanding, oral or otherwise, of the parties or their agents shall be valid or enforceable unless embodied in this IGA.
14. **Severability.** In the event that any portion of this IGA is determined to be void, unconstitutional or otherwise unenforceable, the remainder of this IGA shall remain in full force and effect.
15. **Other Terms and Conditions.**
- A. Nothing in this IGA is intended to, nor shall it be interpreted to, grant or alter any existing jurisdiction of any government over the NATION's public roads. The COUNTY's participation in this IGA is in the spirit of cooperation, and except as expressly set forth herein, the COUNTY shall have no authority, responsibility, or liability in connection with the PROJECTS or the roads that are the subject of the PROJECTS, including road deterioration as a result of road use.
 - B. Neither the NATION nor the COUNTY waives any rights (including but not limited to treaty rights, immunities, sovereign immunities, jurisdictional defenses, or defenses based on their respective protecting laws). Specifically, nothing in this IGA shall be construed as a waiver of sovereign immunity by the NATION, except as provided for in the Navajo Sovereign Immunity Act, as amended, at 1 N.N.C. §§ 551, et seq. Nothing herein shall constitute the NATION's consent to be sued, or consent to jurisdiction of any federal or state court. Nothing in this IGA creates, implies, or shall be construed to create any right of action in any third party.
 - C. Nothing in this IGA is intended to, or shall be interpreted to, allocate or shift any current or future liability of a party to this IGA due to such party's acts or omissions to the other party to this IGA.
 - D. The Navajo Nation acknowledges that it will be responsible for claims of damages arising from personal injury or damages to persons or property to the extent they result from the negligence of tribal employees. The liability of the Navajo Nation shall be subject to the immunities and limitations provided for under the Navajo Nation Sovereign Immunity Act, 1 N.N.C. §§551 et seq.
16. **Dispute Resolution Procedures.** Any dispute arising out of or relating to this IGA shall be resolved by arbitration as contemplated by the Navajo Nation Sovereign Immunity Act, 1 N.N.C. §§ 554(J) and (K), and the Navajo Nation Arbitration Act, 7 N.N.C. §§ 1101 et seq. The arbitration shall be conducted in accordance with the International Institute for Conflict Prevention and Resolution Rules for Non- Administered Arbitration.

Notice of intent to invoke arbitration against the NATION shall be filed in compliance with the notice requirements of the Navajo Nation Sovereign Immunity Act, 1 N.N.C. § 555.

IN WITNESS WHEREOF, the duly authorized representatives of the parties have executed this IGA on the dates affixed by their signatures.

NAVAJO NATION



Jonathan Nez - President

05.18.2022

Date

APACHE COUNTY

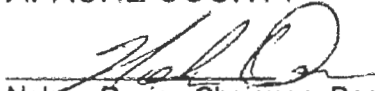

Nelson Davis - Chairman, Board of Supervisors

4/5/2022

Date

ATTEST:



Clerk of the Board

Approved as a form and found to be within the powers and authority of the County Board of Supervisors under the laws of the State of Arizona.

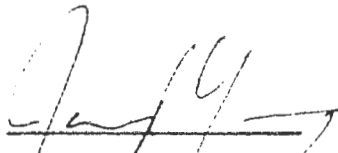

County Attorney

4/9/2022

Date

ATTACHMENT A

PROJECT	FISCAL YEAR	APPROVING RESOLUTION	BUSINESS UNIT	AMOUNT
(N136 Lukachukai)	2021	RDCS-61-14 RDCJA-02-21	C01547.9024	\$185,300.00
Total				\$185,300.00

Scope of Work for N136 Lukachukai:

The improvement will include addressing drainage, subgrade preparation, building up the road where needed, and applying gravel and soil stabilization for up to 2.8 miles.

The County will be responsible for all engineering services but may use the allocated to fund needed engineering services.

The Navajo Division of Transportation will issue a Notice to Proceed to the County, and a Letter of Intent to the Chinle Bureau of Indian Affairs, when project is deemed ready to proceed to the next phase.

Upon completion of the road improvement, the County and Bureau of Indian Affairs will maintain the routes, unless the route is added to Navajo DOT's inventory as a school bus route.

Timeline

Road project needs to be completed before 9/30/22

Funding

Navajo DOT Road Funds: The allocated funds will be used to improve N136 Lukachukai by addressing the drainage, applying gravel, and soil stabilization for up to 2.8 miles. The Navajo Nation funding will not exceed \$185,300.00 which is considered a cost-share to the project.

THE NAVAJO NATION

JONATHAN NEZ | PRESIDENT MYRON LIZER | VICE PRESIDENT



December 30, 2022

APACHE COUNTY, ARIZONA

Nelson Davis, Chairperson
Post Office Box 48
St. Johns, Arizona 85936

Reference: DOC 019739 – CO15782

Dear Mr. Davis:

Attached, please find your executed Intergovernmental Agreement Contract, **CO15782**. This Intergovernmental Agreement Contract is with the Navajo Nation Division of Transportation. This Intergovernmental Agreement Contract is approved in the amount of One Million Two Hundred Fifty-Eight Thousand One Hundred Fifty-Nine Dollars and Sixty-Three Cents (\$1,258,159.63).

This Intergovernmental Agreement Contract will commence on December 5, 2022 and will terminate on December 31, 2032. Contract, **CO15782** must be referenced on all invoices, documents and correspondences as it relates to this contract.

Should you have any questions, please contact Garret Silversmith, Director, Navajo Nation Division of Transportation at 505.371.8335.

Sincerely,

THE NAVAJO NATION

Handwritten signature of Valerie Bitsilly in cursive.

Valerie Bitsilly, Accountant
Contract Administration
Navajo Nation Office of the Controller

Xc: Garret Silversmith, Director, Navajo Nation Division of Transportation
File / CO15782

JAN 2023

ATTACHMENT B

To Intergovernmental Agreement between The NAVAJO NATION and APACHE COUNTY, ARIZONA

Authority:

This Attachment B is appended to the underlying Master Intergovernmental Agreement. Navajo Nation Contract No. CO15355, as contemplated in Sections 1.1 and 2.1 of the Master Agreement.

Term:

Beginning upon signatures of both parties, and Ending December 31, 2032; coinciding with the term of the Master Agreement.

Scopes of Work (SOW):

Project 1 - C492 Round Rock Apache County shall improve County Road 492 in the Round Rock Chapter of the Navajo Nation. The improvement will include addressing drainage, subgrade preparation, building up the road where needed and applying gravel and soil stabilization for up to 5.2 miles. Navajo DOT will complete the cultural & environmental studies and will be responsible for monitoring the project during construction. Upon completion, the County will maintain the route. This project will be funded with Navajo Nation Sihasin funds. A C590/C492 project location map is attached

Project 2 - C590 Round Rock Apache County shall improve County Road 590 in the Round Rock Chapter of the Navajo Nation. The improvement will include addressing drainage, subgrade preparation, building up the road where needed and applying gravel and soil stabilization for up to 3.1 miles. Navajo DOT will complete the cultural & environmental studies and will be responsible for monitoring the project during construction. Upon completion, the County will maintain the route. This project will be funded with Navajo Nation Sihasin funds. A C590/C492 project location map is attached.

Project 3 - N9402 Houck Apache County shall improve N9402 in the Houck Chapter of the Navajo Nation. The improvement will include addressing drainage, subgrade preparation, building up the road where needed and applying gravel and soil stabilization from 2 miles up to 10.3 miles. The County will be responsible for all engineering services. This project will be funded with Navajo Nation Sihasin funds. An N9402 project location map is attached.

Project 4 - Houck Cemetery Access Road Apache County shall improve #145 Cemetery Access Road in the Houck Chapter of the Navajo Nation. Improvements include installing two 36" x 40' culverts with end sections at Location 1; and installing one 36" x 40' culvert with end sections at Location 2. Additionally, grade road using existing earth materials by creating flat bottom ditches and raising centerline profile. This project will be funded with Navajo Nation Sihasin funds. A Proposed Cemetery Road strip map is attached.

Project 5 - N39 Kindalichee Apache County shall improve N39 in the Kinlichee Chapter of the Navajo Nation. Improvements include road maintenance, and gravel placement & stabilizer treatment from 1.5 miles. This project will be funded with Navajo Nation Sihasin funds. An N39 project location map is attached.

Project 6 - N203 Kinlichee Apache County shall improve N203 in the Kinlichee Chapter of the Navajo Nation. Improvements include 2 miles of sub-grade preparation, add soil stabilizer to 2 miles of

road, place 3 inches of FP-14 D gravel road. This project will be funded with Navajo Nation Road funds (FET). An N203 project location map is attached.

Should any of these Scopes of Work or any additional work exceed the amount of the funding source as described herein, the Chapters and Navajo Nation shall find additional funding sources.

Budget:

Attachment B

Project #	District	Route Number & Names	Funding Source	Business Unit	Budget
1	D-1	C492 Round Rock	NN Sihasin	C01762.9024	351,153.69
2	D-1	C590 Round Rock	NN Sihasin	C01763.9024	228,533.94
3	D-2/3	N9402 Houck	NN Sihasin	C01692.9024	85,000.00
4	D-2	Houck Cemetery Access Road	NN Sihasin	N01411.9024	46,722.00
5	D-2	N39 Kindalichee	NN Road Funds	C01650.9024	246,750.00
6	D-2	N203 Kinlichee	NN Road Funds	C01863.9024	300,000.00
Total Attachment "B" Not To Exceed					\$ 1,258,159.63

TOTAL ATTACHMENT "B" NOT TO EXCEED: \$1,258,159.63

IN WITNESS WHEREOF, the PARTIES have executed this ATTACHMENT "B" to the Master Intergovernmental Agreement, on the dates affixed by their signatures.

APACHE COUNTY

THE NAVAJO NATION

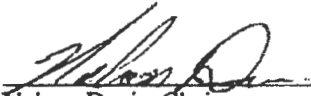
 Nelson Davis, Chairperson
 Apache County Board of Commissioners
 P.O. Box 48
 St. Johns, AZ 85936

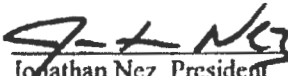
 Jonathan Nez, President
 The Navajo Nation
 P.O. Box 7440
 Window Rock, AZ 86515

11/7/2022
 Date Signed

12.05.2022
 Date Signed

**THIS CONTRACT HAS BEEN REVIEWED
 AND IS IN ACCORDANCE WITH NAVAJO NATION LAW**

BY 
 Navajo Nation Legal Counsel

11/21/22
 Date Signed

**Apache County Board of Supervisors
AGENDA ITEM REVIEW FORM**

Submitter's Name: (Individual, Organization, or County Department)

Engineering _____

Date/Signature 2/21/24  _____

Describe in detail what you want to say to the Board and what action you want the Board to take:

Discussion and possible approval to utilize a sole source vender, Southwestern Scale Company, to purchase and install a new 70'x10' Truck scale at the Carrizo Pit for a cost of \$144,749.83

BOS Meeting Date Requested 2-22-2024

PRE-AGENDA ITEM REVIEW

Review Routing / /Legal / /Finance / /Purchasing / /Human Resource / /Other: _____

Legal Review: OK per Michael

Signature: _____

Finance Review: _____

Signature: _____

Human Resources Review: _____

Signature: _____

Other Review: _____

Signature: _____

Reviews completed; item approved for Agenda. Supervisor/Board Clerk's Initials _____



Quote

#17994

01/24/2024

Bill To
Purchasing
Apache County
P.O. Box 428
Saint Johns AZ 85936
United States

Ship To
Apache County
36.924108, -109.196525
Teec Nos Pos AZ 86514
United States

Customer #	Terms	Sales Rep	Quote Expiration Date
657828	25% Down, Net 30	O'Reilly, Timothy E	02/23/2024

Quote Details

NEW 70' x 11' Above Ground STEEL DECK Truck Scale - Steel deck with wheel curbs, 2 modules, and 12" end-wall height (profile height). NTEP COC# 88-265. 3/8" tread plate run the length of each module. 140,000 x 20 lb. Scale uses 6 (65K) double ended shear beam load cells with braided wire cables (Rodent Protection). All rigid conduit and sealed NEMA 4 rated junction boxes throughout. 10 year warranty on weighbridge, 2 year load cell warranty. Model ships 12'6" outside width and requires 1 truck for shipping.

Contact: John Harris
Apache County
Purchasing Agent/Limestone Quarry Manager
P.O. Box 428
St. Johns, AZ 85936
Office: 928-337-7531
Cell: 928-245-0777
jharris@apachecountyaz.gov

Scope of Work: Form and pour new scale foundation (piers end walls ramps and approaches, build, deliver and install new 70' x 11' steel deck truck scale to be installed above ground.

Notes:

- Lead time on new scales are 16 - 22 weeks ARO (May)
- Any changes in scope or additional parts will be added to the final invoice.
- Applicable taxes to be added on final invoice unless Exempt

Not included in quote:

- Scale house or instrumentation enclosure.
- Conduit from scale house to scale.
- AC power for indicator, printer, remote display.

Special Notes: Weather delays that impact our schedule (outside of our control) such as rain/freezing temps/snow/ice/wind/poor road conditions could result in additional charges that could include travel, labor, material costs and Per Diem. All work is estimated and final invoice will reflect a Time and Materials charge. Materials availability is out of our control. If materials required for the job are on backorder from our preferred vendors SWSCALE may need to source alternates which may impact pricing. Due to current market conditions associated with material, product supply, availability and pricing all quotes will be valid for 10 days until further notice. Further market conditions may require price adjustments to all construction projects based on material costs at project start. Thank you for your understanding and the opportunity to provide you this proposal. Deposits are non refundable.

ISO DECISION RULE: When statements of conformity are provided, the measurement of uncertainty is not taken into consideration when determining those statements. Simple acceptance is used.

UNLEASH THE POWER OF YOUR SCALE DATA
CLICK HERE TO LEARN MORE

PO 8760 Phoenix AZ 85056
602-243-3951
toreilly@swscale.com

Doc #: FRM-016 Rev 1 08/03/2023 ----- Issuing Authority: Sales ----- Page 1 of 3

Qty	Units	Description	Rate	Amount
1	Ea	Sidewinder Truck Scale: Model 70'x11' LPS7070 - Steel deck with wheel curbs, 2 modules, and 12" end-wall height (profile height). NTEP COC# 88-265. 3/8" tread plate run the length of each module. 140,000 x 20 lb. Scale uses 6 (65K) double ended shear beam load cells with braided wire cables (Rodent Protection). All rigid conduit and sealed NEMA 4 rated junction boxes throughout. 10 year warranty on weighbridge, 2 year load cell warranty. Model ships 12'6" outside width and requires 1 truck for shipping.		\$66,953.00
1	Ea	Instrumentation Package to include: Scale Indicator 682+ housed in a rugged IP69 Stainless Steel enclosure with a graphical LCD color display. Multipart Ticket Printer. 40 Column printer with plastic housing 4.7" Stop & Go Remote Display w/Visor & 4" Pole Mount Kit 100' 6 wire home run cable 100' 4 wire communication cable for remote display Printer cable for indicator / printer connection		\$6,411.83
1	Ea	Form and pour a new 70' concrete foundation with 10' approaches and 18' ramps. Includes all construction materials.		\$56,630.00
1	Ea	Scale Installation and calibration. Includes Crane to set scale and Trucking of scale to jobsite		\$14,755.00

WARRANTY - Terms and Conditions: The following provisions form part of the order acknowledged and accepted, as express agreements between Southwestern Scale Company, Inc. and the Buyer governing the terms and conditions of the sale. Any modifications must be in writing and signed by both Seller and Buyer.

1. Southwestern Scale Company warrants their scale against defective parts and workmanship for a period of Ten (10) Years. Defective parts will be made available from our factory, Phoenix Az and do not cover shipping costs. This warranty is void if failure due to overload or the result of construction-foundation shift due to unstable soils, concrete failure, etc.

1) If failure is the result of SITE CONDITIONS - foundation shift, Etc. - It is the owner's responsibility to provide soil reports and to insure that soil will properly support the foundation, not allowing it to shift.

2) If failure is due to Southwestern Scale furnished concrete construction - concrete work will be warranted only if owner obtains test samples at time of the pour and documents the ready-mix company supplied improper concrete.

2. Electronic and mechanical equipment not manufactured by Southwestern Scale used for sensing, indication and printing is warranted for One (1) Year. Electronic Load Cells used with the scale are warranted for Two (2) YEARS - warranty does not cover submersion or arc welding. Warranty does not include Labor, shipping and Trip charges.

3. The seller accepts no liability for special damages, loss of profits, loss of production, or incorrect weighing claims (Meaning incorrect use of scale, driver /truck not positioned on scale properly, errors in entry of weights, operator errors, Driver in truck or out of truck errors, Load shift/modifications after weigh-ment takes place).

4. Construction pricing is based on normal site conditions. If buried items are encountered during excavation, extra costs will be on cost plus 10%.

Subtotal **\$144,749.83**

ISO DECISION RULE: When statements of conformity are provided, the measurement of uncertainty is not taken into consideration when determining those statements. Simple acceptance is used.

**UNLEASH THE POWER OF
YOUR SCALE DATA
CLICK HERE TO LEARN MORE**

PO 3760 Phoenix AZ 85006
602-243-3951
toreilly@swscale.com



Quote

#17994

01/24/2024

CUSTOMER PURCHASE ORDER NO _____

Tax (0%)

\$0.00

Total

\$144,749.83

QUOTE ACCEPTED BY _____

ISO DECISION RULE: When statements of conformity are provided, the measurement of uncertainty is not taken into consideration when determining those statements. Simple acceptance is used.

**UNLEASH THE POWER OF
YOUR SCALE DATA
CLICK HERE TO LEARN MORE**

PO 8760 Phoenix AZ 85066

602-243-3951

torelly@swscale.com

**Apache County Board of Supervisors
AGENDA ITEM REVIEW FORM**

Submitter's Name: (Individual, Organization, or County Department)

Engineering

Date/Signature 2/28/24 

Describe in detail what you want to say to the Board and what action you want the Board to take:

Discussion and possible approval to utilize a Sourcewell contract #58053 with Empire CAT to purchase a new generator for use at the Carrizo Pit for a cost of \$67,701.60

BOS Meeting Date Requested 2-22-2024

PRE-AGENDA ITEM REVIEW

Review Routing / /Legal / /Finance / /Purchasing / /Human Resource / /Other: _____

Legal Review: OK per Michael

Signature: _____

Finance Review: _____

Signature: 

Human Resources Review: _____

Signature: _____

Other Review: _____

Signature: _____

Reviews completed; item approved for Agenda. Supervisor/Board Clerk's Initials _____



Empire Power Systems
840 N 43rd Ave
Phoenix, AZ 85009

Current Date: 02/13/2024
Quotation Number : 02122023 SWGA
Quotation Expires : 3/12/2024

John Harris
Apache County
Purchasing Agent/Limestone Quarry Manager
P.O. Box 428
St. Johns, AZ 85936
Office: 928-337-7531
Cell: 928-245-0777
jharris@apachecountyaz.gov

**Apache County Quarry
Mobile Generator set.
Sourcewell member # 58053**

In accordance with your request, we are pleased to submit the following proposal for the abovementioned project. Empire Power Systems proposes to furnish this equipment at the attached quoted price.

Empire Power Systems is taking **exception** to any specification for this proposal due to the fact that a written specification was not available at bid time for this project.

We will arrange for initial start-up services at no additional charge. These services include an onsite installation and operational inspection of the equipment supplied by Empire Power Systems. A summary of our basic start up scope of work is included in the attached quote document.

The initial diesel fuel required for startup services and testing **is not** included in this proposal.

Thank you for the opportunity to provide the attached quote. Empire Power Systems remains at your disposal for any additional information or assistance that you may require.

Sincerely yours,
Greg Ames
Account Manager
Empire Power Systems
Office 928.714.2825
Mobile 928.606.1815
greg.ames@empire-cat.com



Empire Power Systems
 840 N 43rd Ave
 Phoenix, AZ 85009

Multiquip Sourcewell # 020923MTQ

NEW Multi Quip DCA 70 SSIU4F	List price	Sourcewell Price
• DCA70SSIU4F Gen 70kVA 3Ph Isuzu ,Tier 4F Env	\$80,730.00	\$46,823.40
• TRLR70USH Trailer DCA 70SSI HYD	\$9,430.00	\$5469.40
• Coupler 3" Pintle 25K TRLRMP thru 400	\$120.00	\$69.60
• Batt Chg. 6A DCA20-125 NGA100	\$660.00	\$382.80
• CAMLOK1KITC	\$810.00	\$469.80
• MQPPB70I4F, power balance	\$5560.00	\$4448.00

Availability

4 weeks from date of PO. Subject to change at time of order.

Freight	\$4200.00
Local labor	<u>\$649.00</u>
	\$62,512.00

plus, estimated tax **\$ 5189.00**

TOTAL \$67,701.60 fob St Johns, AZ

This Quote Specifically Excludes:

- Installation and/or permitting.
- Diesel Fuel
- Crane or Rigging at Job Site

Subject to the attached terms and conditions
 This quote automatically expires: 03/13/2024.

Customer Delay:

To the extent that the construction schedule is significantly delayed by customer for any reason, Empire reserves the right to remedy. This remedy could be in various forms, including invoice and payment prior to shipment, progress payments, and/or the accrual of interest charges on undelivered and unpaid goods. Additionally, Empire will also pass along costs of storage and other fees that may result due to the delay.



Empire Power Systems

840 N 43rd Ave

Phoenix, AZ 85009

Commodity Pricing:

Due to current volatility of commodity pricing the above quoted price is subject to change at the time of order.

This proposal is good for 30-days from date of issue.

The undersigned acknowledge that the preceding proposal has been read in its entirety, is understood and is hereby accepted:

Empire Power Systems

Greg Ames

February 13, 2024

Company:

Printed Name:

Signature:

Date:

Purchase Order No:

TERMS & CONDITIONS

A) Customer is responsible for any and all installation of the equipment supplied by Empire Power Systems, unless otherwise specified in writing. All equipment needed to perform any loading or unloading of the equipment supplied by Empire Power Systems is the responsibility of the buyer.

B) Empire Power Systems limits the scope of supply for this quotation to the equipment and services listed in our bill of material. Unless specifically listed in our bill of material, equipment not indicated is assumed to be supplied by others. We have detailed the equipment proposed in the bill of material. Please check it to be certain that it meets your requirements.

C) Empire Power Systems reserves the right to correct any errors or omissions. Standard warranty of the manufacturer applies. Copies are available upon request.

D) Contracts which include penalty or liquidated damage clauses, waivers of subrogation, or naming a third party additionally insured are not acceptable or binding on Empire Power Systems, unless accepted and confirmed in writing by an officer of Empire Power Systems at its Phoenix division office.

E) Unless agreed to in writing Empire Power Systems will not accept purchase orders which:



Empire Power Systems

840 N 43rd Ave
Phoenix, AZ 85009

- Require Empire Power Systems to pay any and all legal expenses for the purchaser in the event of a dispute.
- Require that Empire Power Systems be responsible for design work and/or guarantee that a performance standard for a system be met.
- Require completion and acceptance of the project by the owner before payment.

F) There will be a 25% of order cancellation fee for any orders cancelled, once placed and accepted by Empire Power Systems.

G) Empire Power Systems' standard and extended terms and conditions are included in the quotation and hereby become part of this quotation. These same terms need to be noted on any purchase order received by Empire Power Systems in order to process your order.

H) Empire Power Systems will not be responsible for any labor or material charges by others associated with the start-up and installation of this equipment unless previously agreed upon, in writing by Empire Power Systems.

I) Empire Power Systems is a supplier of materials and related services and not a contractor. Retention is not acceptable.

J) Credit is subject to Empire Power Systems, approval at its sole discretion. This quote in no way constitutes approval of credit.

K) Sales payments are due Net 10; all others Net 30. Unless otherwise agreed in writing by a corporate officer of Empire Southwest, LLC ("Empire"), the purchase of goods (including, but not limited to, new and used equipment, attachments, parts and technology) or services from Empire will be governed solely by Empire's Terms and Conditions of Sales and Service (the "Terms"), which are available at www.empire-cat.com/termsandconditions or such other successor website at which Empire posts its Terms from time to time. A hard copy of the Terms is available upon written request to terms.conditions@empire-cat.com. Empire's Terms are hereby incorporated by reference into this document and all other documents related to your purchase of goods or services from Empire. By purchasing goods or services from Empire, you agree to be bound by Empire's Terms.

Terms and conditions of this quotation govern over any conflict between this document and customer's purchase order or other document.



DCA70SSIU4F

Generator

WhisperWatt™

Prime Rating — 56 kW (70 kVA)

Standby Rating — 62 kW (77 kVA)

3-Phase, 60 Hertz, 0.8 PF

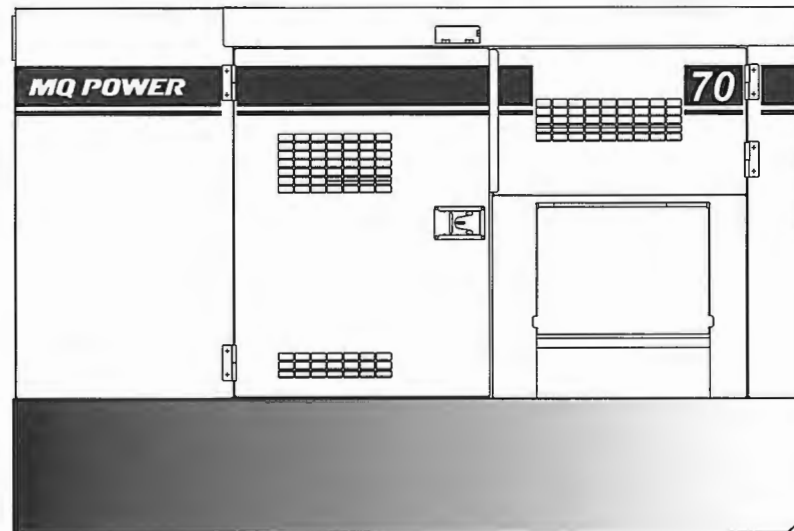

STANDARD FEATURES

- Heavy duty, 4-cycle, direct injection, heated crankcase vent, turbocharged, charge air cooled, 1000W block heater, diesel engine provides maximum reliability.
- EPA emissions certified - Tier 4 Final emissions compliant.
- Microprocessor engine control system maintains frequency to $\pm 0.25\%$.
- Fuel/water separator removes condensation from fuel for extended engine life. Panel-mounted alarm light included.
- Sound attenuated, weather resistant, steel housing provides operation at 65 dB(A) at 23 feet. Fully lockable enclosure allows safe unattended operation.
- E-coat and powder coat paint provide durability and weather protection.
- Internal fuel tank with direct reading fuel gauge.
- Spill containment - Bunded design protects environment by capturing up to 128% of engine fluids.
- Brushless alternator reduces service and maintenance requirements and meets temperature rise standards for Class H insulation systems.
 - Open delta alternator design provides virtually unlimited excitation for maximum motor starting capability.
 - Automatic voltage regulator (AVR) provides precise regulation.
- Fully covered power panel. Three-phase terminals and single phase receptacles allow fast and convenient hookup for most applications including temporary power boxes, tools and lighting equipment. All are NEMA standard.
- ECU845 microprocessor-based digital generator controller.
 - Remote 2-wire start/stop control.
 - High visibility LCD display with heated screen and alphanumeric readout.
 - Operational temperature range of -40° to 85° C.
 - AC monitoring along with fuel and DEF level indicators.
- Digital engine gauges including oil pressure, water temperature, battery volts, engine speed, fuel level and DEF level.
- Analog generator instrumentation including AC ammeter, AC voltmeter, frequency meter, ammeter phase selector switch, voltmeter phase selector switch, and voltage regulator adjustment potentiometer.
- Automatic safety shutdown system monitors the water temperature, engine oil pressure, overspeed, and overcrank. Warning lights indicate abnormal conditions.
- Voltage selector switch offers the operator a wide range of voltages that are manually selectable. Fine tuning of the output voltage can be accomplished by adjusting the voltage regulator control knob to obtain the desired voltage.
- Emergency Stop Switch — when manually activated, shuts down generator in the event of an emergency.



DCA70SSIU4F

Generator

SPECIFICATIONS

Generator Specifications		
Design	Revolving field, self-ventilated Drip-proof, single bearing	
Armature Connection	Star with Neutral	Zig Zag
Phase	3	Single
Standby Output	62 KW (77 KVA)	44 KW
Prime Output	56 KW (70 KVA)	40 KW
3Ø Voltage (L-L/L-N) Voltage Selector Switch at 3Ø 240/139	208Y/120, 220Y/127, 240Y/139	N/A
3Ø Voltage (L-L/L-N) Voltage Selector Switch at 3Ø 480/277	416Y/240, 440Y/254, 480Y/277	N/A
1Ø Voltage (L-L/L-N) (Voltage Selector Switch at 1Ø 240/120)	N/A	240/120
Power Factor	0.8	1.0
Voltage Regulation (No load to full load)	±0.5%	
Generator RPM	1800	
Frequency	60 Hz	
Winding Pitch	2/3	
No. of Poles	4	
Excitation	Brushless with AVR	
Frequency Regulation: No Load to Full Load	Isochronous under varying loads from no load to 100% rated load	
Frequency Regulation: Steady State	±0.25% of mean value for constant loads from no load to full load.	
Insulation	Class H	
Sound Level dB(A) Full load at 23 feet	65	

Engine Specifications	
Make / Model	Isuzu / BR-4JJ1X
Emissions	EPA Tier 4 Final Certified
Starting System	Electric
Design	4-cycle, water cooled, direct injection, turbocharged, charge air cooled, DOC and SCR
Displacement	183.0 in ³ (2999 cc)
No. cylinders	4
Bore x Stroke (mm)	95.4 x 104.9
Gross Engine Power Output	95.2 hp (71 kW)
BMEP	208 psi (1434 kPa)
Piston Speed	1237 ft./min. (6.29 m/s)
Compression Ratio	16.5:1
Engine Speed	1800 rpm
Overspeed Limit	2070 rpm
Oil Capacity	3.96 gallons (15 liters)
Battery	12V 75Ah x 1

Fuel System		
Recommended Fuel	ASTM-D975-No.1 & No.2-D*	
Maximum Fuel Flow (per hour)	16 gallons (60 liters)	
Maximum Inlet Restriction (Hg)	2.9 in. (73.6 mm)	
Fuel Tank Capacity	103 gallons (390 liters)	
Fuel Consumption	gph	lph
At full load	4.4	16.6
At 3/4 load	3.5	13.4
At 1/2 load	2.6	9.8
At 1/4 load	1.7	6.4
DEF Tank Capacity	7.4 gallons (28 liters)	

* - Use ultra-low sulfur diesel fuel.

Cooling System	
Fan Load	4.7 hp (3.5 kW)
Coolant Capacity (with radiator)	5.5 gallons (21 liters)
Coolant Flow Rate (per minute)	15.9 gallons (60 liters)
Heat Rejection to Coolant (per minute)	2483 Btu (2.62 MJ)
Maximum Coolant Friction Head	1.2 psi (7.9 kPa)
Maximum Coolant Static Head	3.3 feet (1.0 meter)
Ambient Temperature Rating	104°F (40°C)

Air	
Combustion Air	138 cfm (3.9 m ³ /min)
Maximum Air Cleaner Restriction	25 in. H ₂ O (6.25 kPa)
Alternator Cooling Air	526 cfm (14.9 m ³ /min)
Radiator Cooling Air	3700 cfm (105 m ³ /min)
Minimum Air Opening to Room	6.03 ft ² (0.56 m ²)
Minimum Discharge Opening	3.33 ft ² (0.31 m ²)

Exhaust System	
Gas Flow (full load)	272 cfm (7.7 m ³ /min)
Gas Temperature	572°F (300°C)
Maximum Back Pressure	7.2 in. H ₂ O (17.5 kPa)

Amperage	
Rated Voltage	Maximum Amps
1Ø 120 Volt	155.4 Amps (4 wire) 168A x 2 (Zigzag)
1Ø 240 Volt	77.8 Amps (4 wire) 168A (Zigzag)
3Ø 240 Volt	168 Amps
3Ø 480 Volt	84 Amps
Main Line Circuit Breaker Rating	200 Amps
Over Current Relay Trip Set Point 480V Mode Only	84 Amps

WARRANTY*

Isuzu Engine**

12 months from date of purchase with unlimited hours or 36 months from date of purchase with 3,000 hours (whichever occurs first).

Generator

24 months from date of purchase or 2,000 hours (whichever occurs first).

Trailer

12 months excluding normal wear items.

*Refer to the express written, one-year limited warranty sheet for additional information.

**Refer to Isuzu Diesel Engine Limited Warranty for details.

NOTICE

Specifications sheet is subject to change and is not intended for use in installation design.



DCA70SSIU4F

Generator

SKID-MOUNT DIMENSIONS

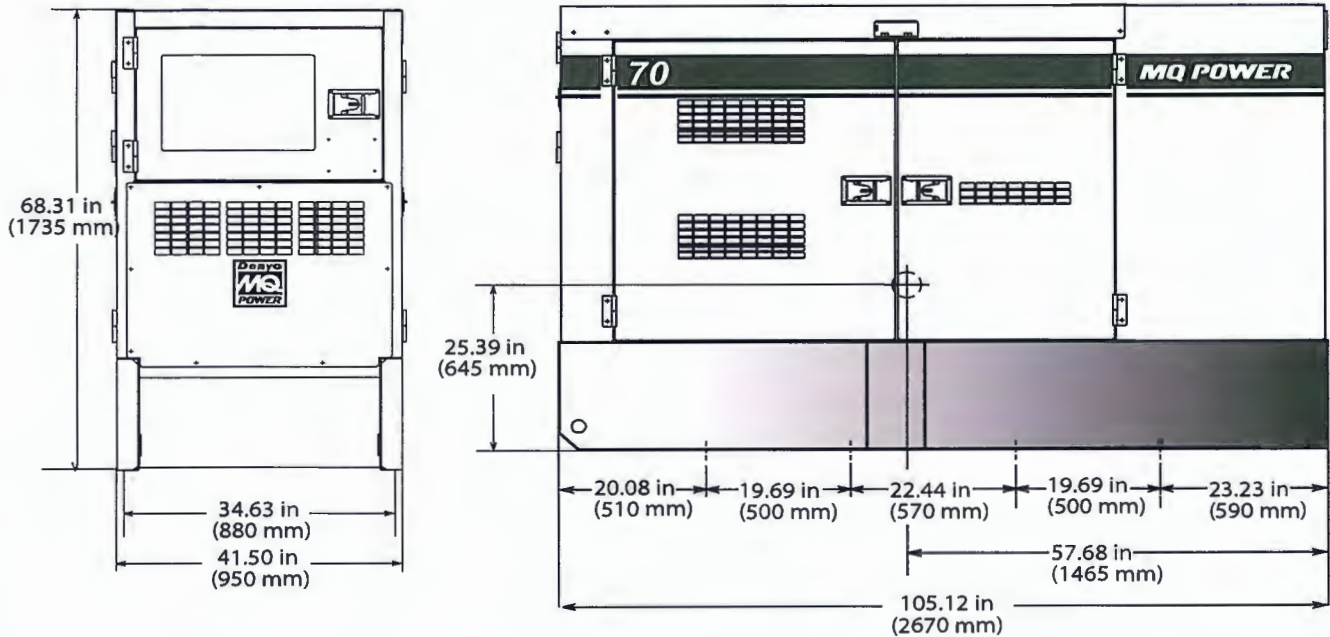

TRAILER-MOUNT DIMENSIONS

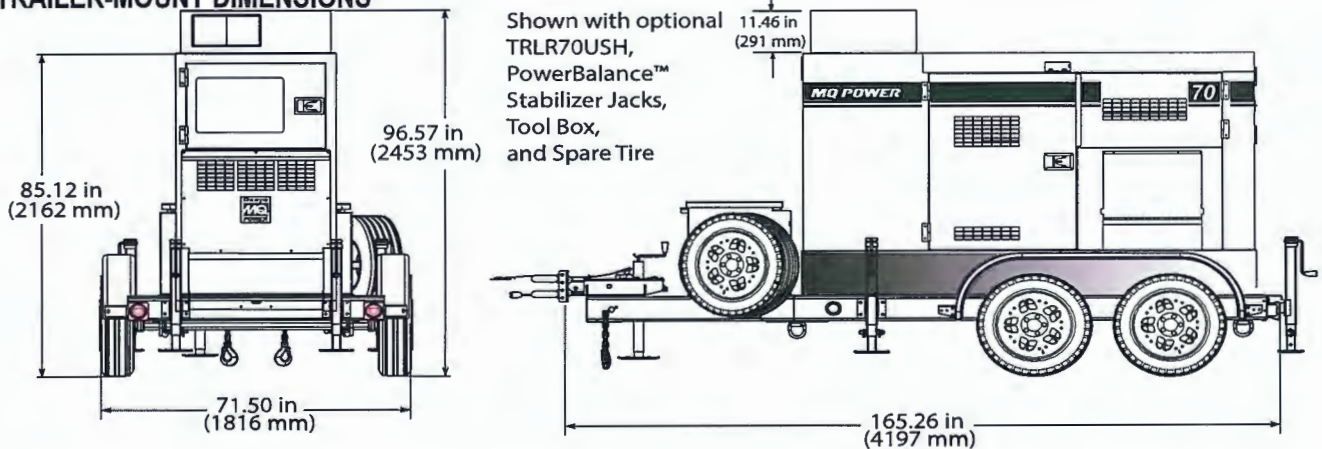

DCA70SSIU4F Weights*	
Dry Weight	3,326 lbs. (1,509 kg)
Wet Weight	4,207 lbs. (1,908 kg)
Max. Lifting Point Capacity	6,960 lb. (3,157 kg)

* Weights do not include options.

DCA70SSIU4F and TRLR70US Weights*	
Dry Weight (with TRLR70US)	4,415 lbs. (2,003 kg)
Wet Weight (with TRLR70US)	5,296 lbs. (2,402 kg)

Generator can be placed on MQ Trailer Models TRLR70US and TRLR125XF2.

NOTICE
Features and Specifications are subject to change without notice.



MULTIQUIP
6141 Katella Avenue Suite 200
Cypress, CA 90630
310-537-3700
E-MAIL: mq@multiquip.com
WEBSITE: www.multiquip.com



DCA70SSIU4F

Generator

MQ POWER DECIBEL LEVELS

Our soundproof housing allows substantially lower operating noise levels than competitive designs. WhisperWatts are at home on construction sites, in residential neighborhoods, and at hospitals — just about anywhere.

- 90 — Subway / truck traffic
- 80 — Average city traffic
- 70 — Inside car at 60 mph
- 60 — Air conditioner at 20 feet
- 50 — Normal conversation

WhisperWatt at 23 feet

65.0
DECIBELS

GENERATOR OUTPUT PANEL

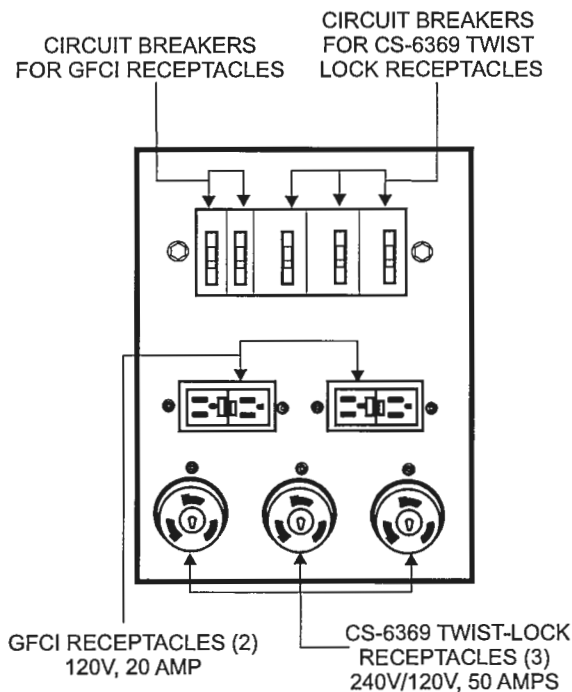

OPTIONAL GENERATOR FEATURES

- **PowerBalance™** — designed to assist generators when operating under low temperature and/or low load conditions to insure peak performance.
- **Battery Charger** — provides fully automatic and self-adjusting charging to the generator's battery system.
- **Trailer Mounted Package** — meets National Highway Traffic Safety Administration (NHTSA) regulations. Trailer is equipped with electronic or surge brakes with double axle configuration.

OPTIONAL CONTROL FEATURES

- **Audible Alarm** — alerts operator of abnormal conditions.

OPTIONAL FUEL CELL FEATURES

- **Sub-base Fuel Cells (double wall)** — additional fuel cell for extended runtime operation. Contains a leak sensor, low fuel level switch, and a secondary containment tank. UL142 listed.
- 12 hours of minimum run time.
- 24 hours of minimum run time.

OPTIONAL OUTPUT CONNECTIONS

- **Cam-Lok Connectors** — provides quick disconnect alternative to bolt-on connectors.
- **Pin and Sleeve Connectors** — provides industry standard connectors for all voltage requirements.
- **Output Cable** — Available in any custom length and size configuration.

**Apache County Board of Supervisors
AGENDA ITEM REVIEW FORM**

Submitter's Name: (Individual, Organization, or County Department)

Engineering

Date/Signature 2/21/24 

Describe in detail what you want to say to the Board and what action you want the Board to take:

Discussion and possible approval to utilize state contract CTR069677 with American Fence Company to install a perimeter security fence around the Carrizo Pit in the amount of \$231,468.25

BOS Meeting Date Requested 2-22-2024

PRE-AGENDA ITEM REVIEW

Review Routing / /Legal / /Finance / /Purchasing / /Human Resource / /Other: _____

Legal Review: OK per Michael

Signature: _____

Finance Review: _____

Signature: 

Human Resources Review: _____

Signature: _____

Other Review: _____

Signature: _____

Reviews completed; item approved for Agenda. Supervisor/Board Clerk's Initials _____



7301 1st Street, Prescott Valley, Arizona 86314
PHONE: (928) 772-6320 FAX: (928) 772-0736
WEB SITE: <http://www.americanfence.com>

2/6/24

Apache County
Attention: John Harris
PO Box 428
St. Johns, AZ 85936

RE: Gravel Pit

Please accept this letter as a bid to furnish and install fence for the above referenced project, as per the following scope of work. All pricing has been generated using **State of Arizona Contract CTR069677**. A breakdown of materials and labor per the contract has also been attached.

Gravel Pit Chainlink Fence - \$231,468.25

- 5,220 LF – 6' chainlink fence with barbwire and razor wire (shop drawing attached)
- 1 EA – 20' wide double swing gate with hold open devices (shop drawing attached)
- 1 EA - Mobilization
- 1 EA - Tax

Exclusions:

- No Performance Bond (can be added for 1% of contract value)
- No engineering
- No Staking
- No removal of spoils, spread on site

The amounts and terms listed herein are guaranteed for a period of 30 days from the date of this letter. If you have any questions, please do not hesitate to call upon the undersigned. We do appreciate the opportunity to submit a bid on this project.

Sincerely,
AMERICAN FENCE COMPANY OF AZ INC

Brian Nickell
Project Manager

Kip Garasha
Regional Manager

R55120N

American Fence Co. of Arizona

Page- 1

7301 1ST ST.

Date- 02/06/24

Quote

PRESCOTT VALLEY, AZ 86314

Time- 09.02.36

Phone (928) 772-6320 Fax (928) 772-0736

AZ Contractor License Number ROC 016349

*** THIS IS NOT AN INVOICE ***

*** THIS IS NOT A LOADING SLIP ***

Order Number 290463 BQ
Customer PO Number . CONTRACT CTR069677

Taken By . . GARASHA K

Sold To:
547351 APACHE COUNTY ENGINEERING
PO BOX 238
ST JOHNS, AZ 85936
(928) 674-3447

Ship To:
547351 APACHE COUNTY ENGINEERING
PO BOX 238
ST JOHNS, AZ 85936
(928) 674-3447

Description	UM	Order	Open	Unit Price	Open Price	Ordered Price
72" 9GA 2" 1.2 GBW KB FABRIC	FT	5200	5200	5.0200	26104.00	26104.00
15/8 X AP-40 PIPE FOOTAGE GALVANIZED TUBE	FT	5502	5502	3.1600	17386.32	17386.32
TENSION WIRE MARCELLED 7 GA 1.2 OZ - 1176 FT PER ROLL	FT	5880	5880	.1400	823.20	823.20
4PT 12 1/2 GA CLASS 1 DOM 5"SP RO BARBED WIRE	RO	12	12	153.1800	1838.16	1838.16
2 3/8 X 10' 6" AP-40 GALVANIZED TUBE	PC	15	15	55.8600	837.90	837.90
1 7/8 X 8' AP-40 GALVANIZED TUBE	PC	508	508	31.4400	15971.52	15971.52
4" X AP-40 FOOTAGE 2 - 4" X 10'6" AP40	FT	21	21	11.5400	242.34	242.34
18" HELICAL 33LPS STD BARB GALV TAPE CLASS III WIRE	RO	110	110	72.1400	7935.40	7935.40
BALL CAP 2 3/8 PS	EA	15	15	2.1000	31.50	31.50
BALL CAP 4" PS	EA	2	2	4.3900	8.78	8.78
BARB ARM 1 7/8 X 1 5/8 PS 45 DEGREE	EA	508	508	5.3400	2712.72	2712.72
SLEEVE 1 5/8 X 6 PS	EA	240	240	2.1800	523.20	523.20

R55120N

American Fence Co. of Arizona
7301 1ST ST.

Page- 2
Date- 02/06/24
Time- 09.02.36

Quote

PRESCOTT VALLEY, AZ 86314
Phone (928) 772-6320 Fax (928) 772-0736
AZ Contractor License Number ROC 016349

*** THIS IS NOT AN INVOICE ***
*** THIS IS NOT A LOADING SLIP ***

Order Number 290463 BQ
Customer PO Number . CONTRACT CTR069677

Taken By . . GARASHA K

Sold To:
547351 APACHE COUNTY ENGINEERING
PO BOX 238
ST JOHNS, AZ 85936
(928) 674-3447

Ship To:
547351 APACHE COUNTY ENGINEERING
PO BOX 238
ST JOHNS, AZ 85936
(928) 674-3447

Description	UM	Order	Open	Unit Price	Open Price	Ordered Price
TENSION BAR 70" 3/16"X3/4" GALV	EA	32	32	3.8900	124.48	124.48
BRACE BAND 2 3/8 REG 12GA X 3/4"	EA	180	180	1.0800	194.40	194.40
BRACE BAND 1 7/8 REG 12GA X 3/4"	EA	32	32	.8700	27.84	27.84
BRACE BAND 4 REG 12GA X 3/4"	EA	12	12	1.6100	19.32	19.32
TENSION BAND 2 3/8 REG 14GA X 3/4"	EA	150	150	.9400	141.00	141.00
TENSION BAND 4 REG 14GA X 3/4"	EA	10	10	1.3800	13.80	13.80
RAIL-END 1 5/8 PS	EA	64	64	1.9800	126.72	126.72
RAIL-END 1 5/8 2-HOLE PS	EA	32	32	2.4500	78.40	78.40
TIE 6 1/2" 12 1/2 GA GALV	EA	5300	5300	.0800	424.00	424.00
CARRIAGE BOLT 5/16 X 1 1/4 GALV W/NUT	EA	400	400	.1800	72.00	72.00
HOG RINGS 9 GA CLASS I GALV 25LBS/BOX	LB	30	30	3.9100	117.30	117.30
TRUSS ROD THREADED 12' GALV 3/8 DIAM W/NUT	EA	32	32	6.9200	221.44	221.44

R55120N

American Fence Co. of Arizona

Page- 3

7301 1ST ST.

Date- 02/06/24

Quote

PRESCOTT VALLEY, AZ 86314

Time- 09.02.36

Phone (928) 772-6320 Fax (928) 772-0736

AZ Contractor License Number ROC 016349

*** THIS IS NOT AN INVOICE ***

*** THIS IS NOT A LOADING SLIP ***

Order Number 290463 BQ
Customer PO Number . CONTRACT CTR069677

Taken By . . GARASHA K

Sold To:
547351 APACHE COUNTY ENGINEERING
PO BOX 238
ST JOHNS, AZ 85936
(928) 674-3447

Ship To:
547351 APACHE COUNTY ENGINEERING
PO BOX 238
ST JOHNS, AZ 85936
(928) 674-3447

Description	UM	Order	Open	Unit Price	Open Price	Ordered Price
TRUSS TIGHTENER INDUSTRIAL PS	EA	32	32	2.8100	89.92	89.92
IND HINGE 180 4 X 1 5/8 OR 1 7/8 PS	EA	4	4	18.3000	73.20	73.20
GATE PER SQUARE FT 1 7/8 AP40 20 X 6 CHHAINLINK DD GATE	EA	120	120	10.0600	1207.20	1207.20
ADD BARBWIRE TO GATE - PR FT 4PT BARBWIRE	EA	20	20	6.0800	121.60	121.60
CONCRETE	CY	9	9	208.5000	1876.50	1876.50
LABOR, PER MAN HOU	MH	2200	2200	65.0000	143000.00	143000.00
4000 COMMERCIAL STRONG ARM GATE LATCH	EA	1	1	113.0700	113.07	113.07
DUCKBILL HOLDBACK MALL	EA	2	2	14.8400	29.68	29.68
HOG RINGS 12 1/2 GA GALV	LB	35	35	4.3900	153.65	153.65

Order Total- 222640.56 222640.56

Taxable Amount- 222640.56 @ 3.965 % Tax 8827.69

Quote Total- 231468.25

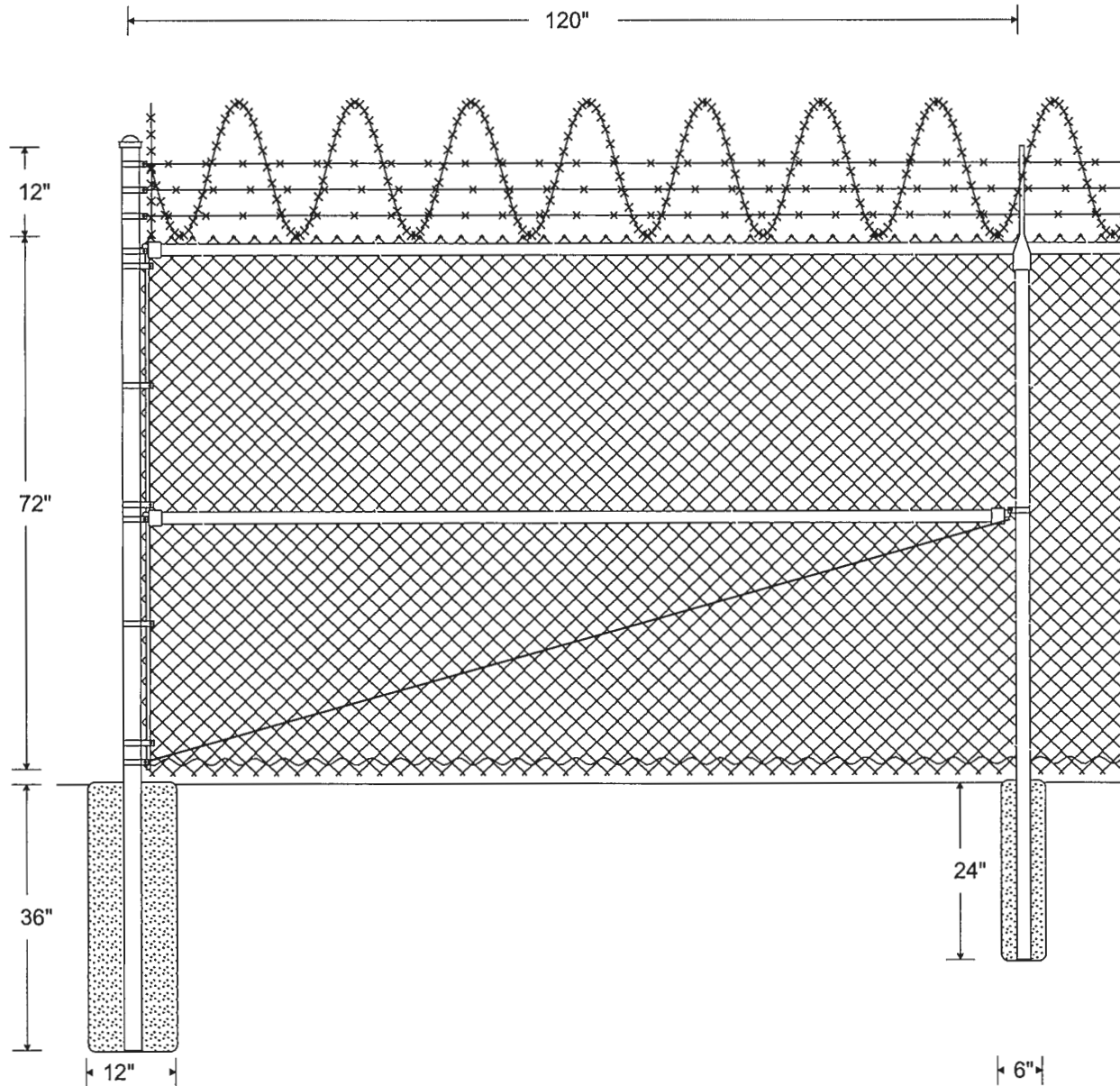

FABRIC: 72" 9 GA. GBW (2" Mesh) KB
CHAIN LINK FABRIC.

TOP RAIL: 1 5/8" O.D. AP-40 PIPE,
1.84 lbs. per foot. Top rail 21'
in length, joined with 1 5/8"
SLEEVE.

LINE POST: 1 7/8" O.D. AP-40 PIPE,
2.28 lbs. per foot. Line posts set
10' on center maximum spacing.
Concrete footing: 6" diameter, 24"
depth.

TERMINAL POST: 2 3/8" O.D. AP-40
PIPE, 3.12 lbs. per foot. Concrete
footing: 12" diameter, 36" depth.

BRACING: Terminal posts braced and
trussed to the nearest line post
with 1 5/8" O.D. AP-40 PIPE and
3/8" TRUSS ROD & IND. TRUSS ROD
TIGHTENER.

TENSION WIRE: 7 GA. COIL SPRING
GALV. TENSION WIRE attached to
bottom of fence fabric with 9 GA.
STEEL HOG RING spaced 24" on
center.

BARBED WIRE: 3 strands of 4 PT. 12
1/2 CLASS 1 DOM 5" BARB WIRE on 45
Deg. PRESSED STEEL BARB WIRE ARM.

OBSTACLE WIRE: 18" DIA. GALV./GALV.
RAZOR RIBBON attached with 12 1/2
GA. STEEL HOG RING.

FITTINGS: REGULAR BRACE BAND &
CARRIAGE BOLT, PRESSED STEEL
RAIL-END, 45 Deg. PRESSED STEEL
BARB WIRE ARM, PRESSED STEEL CAP,
3/16" X 3/4" TENSION BAR, REGULAR
TENSION BAND & CARRIAGE BOLT.

TIE WIRE: 6 1/2" 11 GA. STEEL TIE
WIRE spaced 15" on center for line
posts & 24" on center for rails.

AMERICAN
FENCE COMPANY
Securing America Since 1948

AMERICAN FENCE COMPANY
2502 N 27TH AVE
PRESCOTT VALLEY, AZ 85009
(602) 272-2333

LINE OF FENCE

Drawn: 02/06/2024
File:

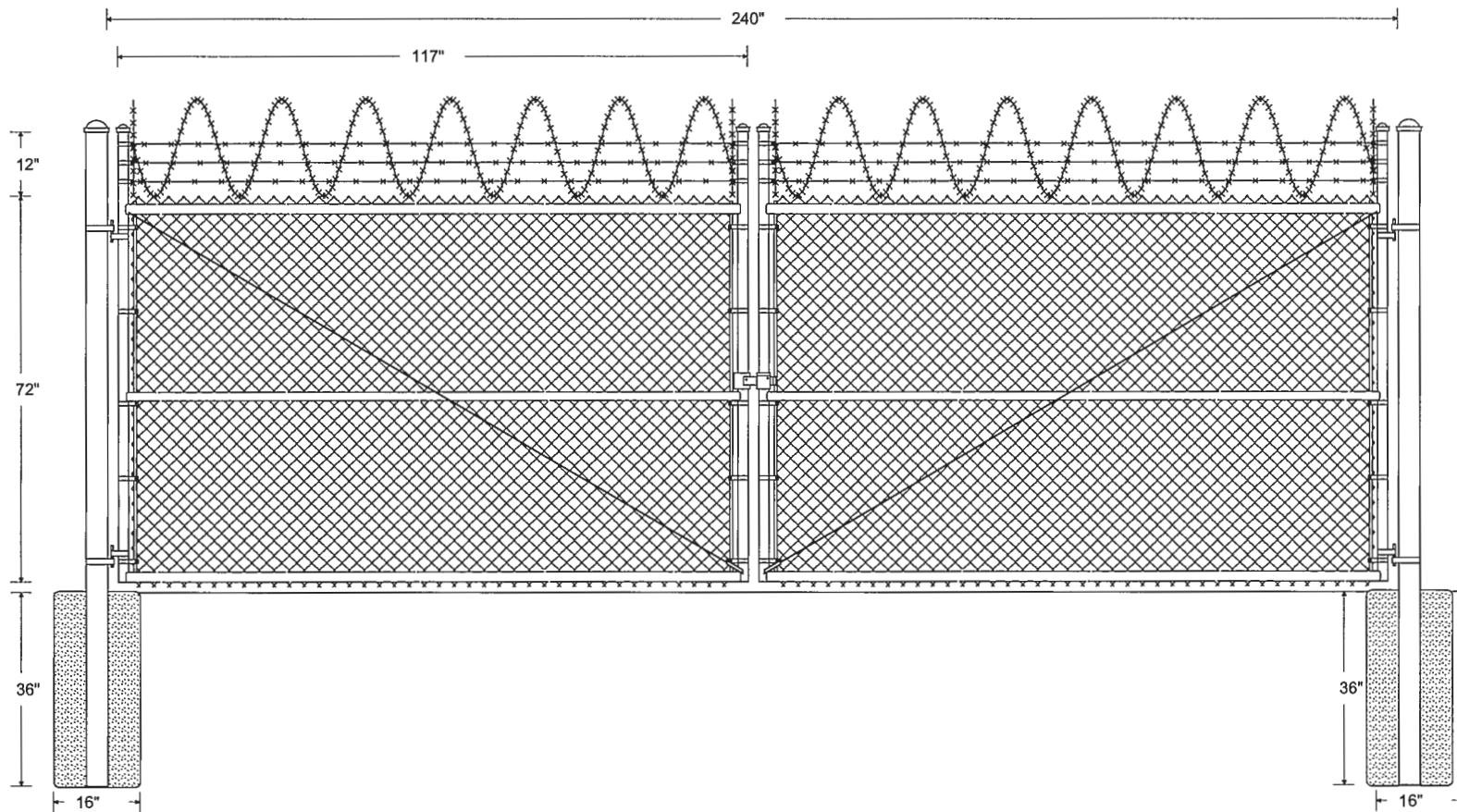

FABRIC: 72" 9 GA. GBW (2" Mesh) KB CHAIN LINK FABRIC.

BRACING: Terminal posts braced and trussed to the nearest line post with 1 5/8" O.D. AP-40 PIPE and 3/8" TRUSS ROD & IND. TRUSS ROD TIGHTENER.

GATES: Framework of 1 7/8" AP-40 PIPE, 2.28 lbs. per foot. Gates braced and trussed as necessary. Same fabric as fence. Barbed wire included on all gates.

GATE POST: 4" O.D. AP-40 PIPE, 6.56 lbs. per foot. Concrete footing: 16" diameter, 36" depth.

BARBED WIRE: 3 strands of 4 PT. 12 1/2 CLASS 1 DOM 5" BARB WIRE on 45 Deg. PRESSED STEEL BARB WIRE ARM.

OBSTACLE WIRE: 18" DIA. GALV./GALV. RAZOR RIBBON attached with 12 1/2 GA. STEEL HOG RING.

FITTINGS: REGULAR BRACE BAND & CARRIAGE BOLT, PRESSED STEEL RAIL-END, 45 Deg, PRESSED STEEL BARB WIRE ARM, PRESSED STEEL CAP, 3/16" X 3/4" TENSION BAR, REGULAR TENSION BAND & CARRIAGE BOLT.

TIE WIRE: 6 1/2" 11 GA. STEEL TIE WIRE spaced 15" on center for line posts & 24" on center for rails.

POST FOOTING: CU. YD. CONCRETE.

AMERICAN
FENCE COMPANY
Securing America Since 1948

AMERICAN FENCE COMPANY
2502 N 27TH AVE
PRESCOTT VALLEY, AZ 85009
(602) 272-2333

20' DOUBLE GATE, 1 7/8" AP-40 PIPE FRAME

Drawn: 02/06/2024
File: